

Advanced
Rotating
Machinery
Dynamics

TORSION

Version 6.2

**New
Release**

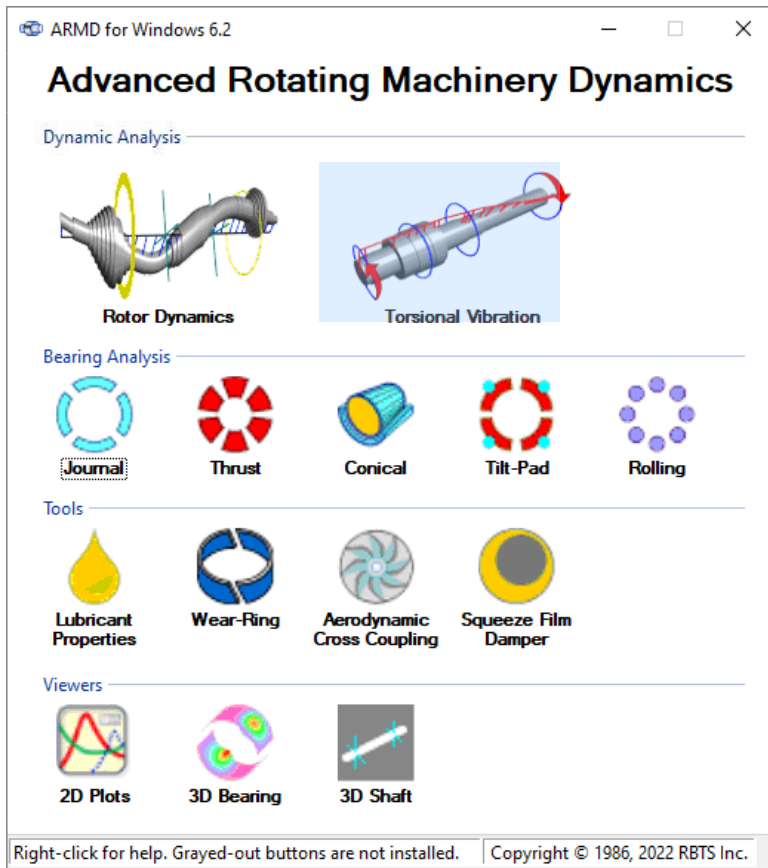

**TORSIONAL
VIBRATION
(TORSION)**

**Natural
Frequencies
& Mode
Shapes
(TORNAT)**

**Steady State
Response
(TORHRM)**

**Time
Transient
Response
(TORRSP)**

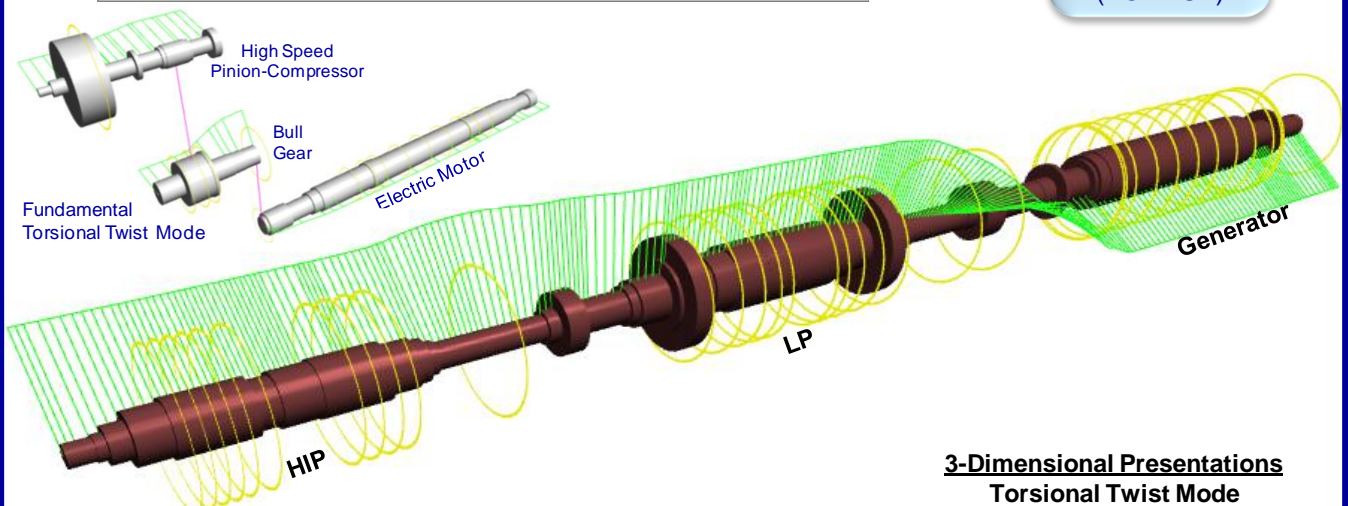

Please contact **Dr. Andreas Laschet** as RBTS' consultant and representation for the regions **Europe, Middle East, Africa** with the following communication details:

Laschet Consulting GmbH · Friedrich-Ebert-Str. 75 · 51429 Bergisch Gladbach · GERMANY
Phone: +49 2204 84-2630 · E-mail: info@laschet.com · Web: www.laschet.com



The torsional vibration package uses a finite-element based formulation for performing damped and undamped torsional **natural frequencies** and **mode shapes** (TORNAT), **steady-state** (TORHRM) and **time-transient** (TORRSP) **response** of mechanical drive trains. The three sub-modules are integrated by TORSION's user interface. The user interface controls the sub-modules to provide a complete torsional vibration analysis environment. TORSION accepts/imports models generated with the rotor dynamics package "ROTLAT" and has advanced modeling features and capabilities including the modeling of multi-shaft/multi-branch systems, coupling stiffness and damping, gear tooth flexibility, stiffness/mass/inertia diameter, torsional springs to ground, various types of external excitations, synchronous motor start-up torque, compressor load torque, user specified time varying torques, electrical faults for motor and generator, and many others.

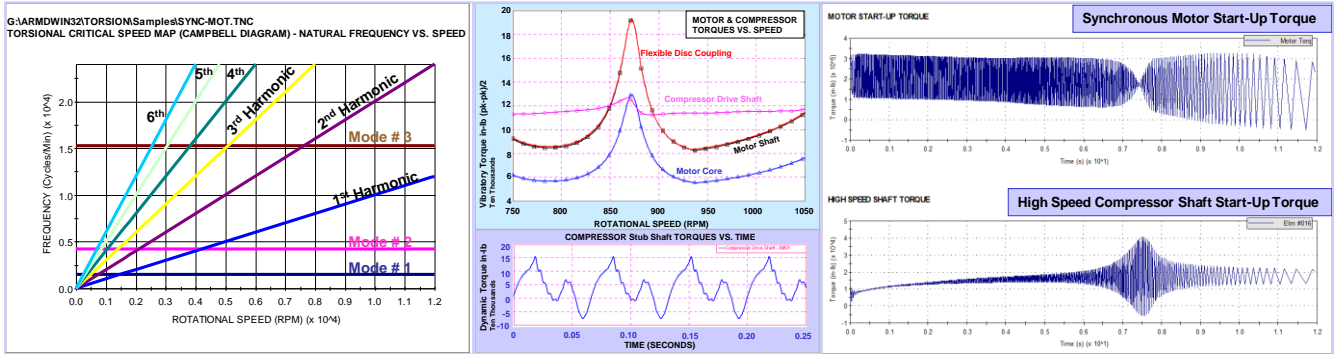

- **The release of RBTS' ARMD Version 6 Torsion is a major milestone in the product's development history, rolling out a completely new and improved graphical user interface for the package with enhanced numerical capabilities and features. The software's front end was redesigned with our customers' and industry's input to incorporate the most logical, efficient, and productive techniques to model and analyze complex multi-shaft systems for torsional vibrations.**

ARMD TORSION users will immediately see the improvements as element, shaft, and system data are presented in a flatter format, with key fields and analysis options readily visible and accessible from the main data entry screens. Engineering productivity to design models is vastly improved as shafts and systems can be easily imported from user-generated component template models. Furthermore, the ability to simultaneously run multiple instances of the program permits rapid side-by-side comparison of results.

By identifying new trends from industry standards, along with RBTS' involvement in turbomachinery standards revisions, new technical features were added to the software. Addition of equivalent torsional stiffness diameters, better handling of shaft connections, expanded user-defined torques application, and better access to temperature dependent properties all combine to provide more accurate modeling and better matching of analysis results to actual system empirical results.

ARMD™ V6.2 – TORSION Package

Among The Enhanced Modeling, Usability and Technical Features are:

- **Improved TAB layout.** Redesigned for more direct and faster access to data input locations, and results. - Important functionality is brought forward into the TAB structure, thereby eliminating the need to select from drop down menu lists and mouse right-click drop down menu lists.

The screenshot displays three overlapping windows from the TORSION software. The top window is the 'System' window, showing a table of element properties. The middle window is the 'Options' window, showing simulation parameters. The bottom window is the 'Applied Torque Tables' window, showing a table of torque data.

Material Number	Use Geometry	Taper	Length	OD1	ID1	OD2	ID2	Use Stiffness Diam	Stiffness Diameter	Stiffness	Damping	Inertia	Use Dyn Mag	Dynamic Magnifier	Name
1	<input checked="" type="checkbox"/>	<input type="checkbox"/>	11.0	7.5	2.36	7.5	2.36	<input type="checkbox"/>	0.0	0.0	0.0	0.0	<input type="checkbox"/>	0.0	MOTOR NDE
2	<input checked="" type="checkbox"/>	<input type="checkbox"/>	14.0	8.0	2.36	8.0	2.36	<input type="checkbox"/>	0.0	0.0	0.0	0.0	<input type="checkbox"/>	0.0	
3	<input checked="" type="checkbox"/>	<input type="checkbox"/>	10.0	9.0	2.36	9.0	2.36	<input type="checkbox"/>	0.0	0.0	0.0	0.0	<input type="checkbox"/>	0.0	
4	<input checked="" type="checkbox"/>	<input checked="" type="checkbox"/>	20.0	9.0	2.36	11.0	2.36	<input type="checkbox"/>	0.0	0.0	0.0	0.0	<input type="checkbox"/>	0.0	

The 'Options' window shows the following parameters:

- Control / Constant Speed / Startup options
- Material Fatigue / Life Data
- Gear Backlash
- Control parameters: Time step size for integration (sec) = 1.000000e-04, Number of simulation time steps = 120000
- Constant speed / startup and shutdown options: Perform Time-Transient Response at fixed speed using the following features: Predefined external torque

The 'Applied Torque Tables' window shows the following table:

Branch	Station	Start Time	CSV File	Status	Browse	Edit	Name
1	1	6	0.05 My TData_01.csv	Found			Torque data from CSV file.

- **Multiple instances of TORSION.** The newly developed package can now **open simultaneously multiple instances of TORSION**, so shafts and component models can be moved easily between different models, also allowing fast, side-by-side comparison of model variations and analysis results. This functionality permits multiple instances of TORSION Version 6 or Version 5.8 to be accessible on your screens.

The screenshot shows a window titled 'TORSION Instance #1 Turbine-Generator-Model'. The window displays a table with columns for 'Total Elements', 'Speed', and 'Branch Name'. The table contains one row with the following data:

Total Elements	Speed	Branch Name
499	1800.01	Turbine Generator Set

The screenshot shows a window titled 'TORSION Instance #2 Synchronous Motor'. The window displays a table with columns for 'Material Number', 'Use Geometry', 'Taper', 'Length', 'OD1', 'ID1', 'OD2', 'ID2', 'Use Stiffness Diam', 'Stiffness Diameter', 'Stiffness', 'Damping', 'Inertia', 'Use Dyn Mag', 'Dynamic Magnifier', and 'Name'. The table contains 14 rows of data:

Material Number	Use Geometry	Taper	Length	OD1	ID1	OD2	ID2	Use Stiffness Diam	Stiffness Diameter	Stiffness	Damping	Inertia	Use Dyn Mag	Dynamic Magnifier	Name
1	<input checked="" type="checkbox"/>	<input type="checkbox"/>	11.0	7.5	2.36	7.5	2.36	<input type="checkbox"/>	0.0	0.0	0.0	0.0	<input type="checkbox"/>	0.0	MOTOR NDE
2	<input checked="" type="checkbox"/>	<input type="checkbox"/>	14.0	8.0	2.36	8.0	2.36	<input type="checkbox"/>	0.0	0.0	0.0	0.0	<input type="checkbox"/>	0.0	
3	<input checked="" type="checkbox"/>	<input type="checkbox"/>	10.0	9.0	2.36	9.0	2.36	<input type="checkbox"/>	0.0	0.0	0.0	0.0	<input type="checkbox"/>	0.0	
4	<input checked="" type="checkbox"/>	<input type="checkbox"/>	20.0	9.0	2.36	11.0	2.36	<input type="checkbox"/>	0.0	0.0	0.0	0.0	<input type="checkbox"/>	0.0	
5	<input checked="" type="checkbox"/>	<input type="checkbox"/>	15.0	14.0	0.0	15.0	0.0	<input type="checkbox"/>	0.0	0.0	0.0	0.0	<input type="checkbox"/>	0.0	MOTOR CORE
6	<input checked="" type="checkbox"/>	<input type="checkbox"/>	20.0	14.0	0.0	20.0	0.0	<input type="checkbox"/>	0.0	0.0	0.0	0.0	<input type="checkbox"/>	0.0	MOTOR CORE
7	<input checked="" type="checkbox"/>	<input type="checkbox"/>	15.0	14.0	0.0	15.0	0.0	<input type="checkbox"/>	0.0	0.0	0.0	0.0	<input type="checkbox"/>	0.0	MOTOR CORE
8	<input checked="" type="checkbox"/>	<input type="checkbox"/>	15.0	14.0	0.0	15.0	0.0	<input type="checkbox"/>	0.0	0.0	0.0	0.0	<input type="checkbox"/>	0.0	MOTOR CORE
9	<input checked="" type="checkbox"/>	<input type="checkbox"/>	15.0	14.0	0.0	15.0	0.0	<input type="checkbox"/>	0.0	0.0	0.0	0.0	<input type="checkbox"/>	0.0	MOTOR CORE
10	<input checked="" type="checkbox"/>	<input type="checkbox"/>	14.0	0.0	0.0	0.0	0.0	<input type="checkbox"/>	0.0	0.0	0.0	0.0	<input type="checkbox"/>	0.0	
11	<input checked="" type="checkbox"/>	<input type="checkbox"/>	10.0	0.0	0.0	0.0	0.0	<input type="checkbox"/>	0.0	0.0	0.0	0.0	<input type="checkbox"/>	0.0	MOTOR DE
12	<input checked="" type="checkbox"/>	<input type="checkbox"/>	27.0	7.0	0.0	7.0	0.0	<input type="checkbox"/>	0.0	0.0	0.0	0.0	<input type="checkbox"/>	0.0	LS COUPLING
13	<input checked="" type="checkbox"/>	<input type="checkbox"/>	21.0	7.5	0.0	7.5	0.0	<input type="checkbox"/>	0.0	0.0	0.0	0.0	<input type="checkbox"/>	0.0	LS GEAR SHAFT
14	<input checked="" type="checkbox"/>	<input type="checkbox"/>	23.0	16.0	0.0	16.0	0.0	<input type="checkbox"/>	0.0	0.0	0.0	0.0	<input type="checkbox"/>	0.0	LS GEAR

ARMD™ V6.2 – TORSION Package

Many of the improvements incorporated into the ARMD TORSION Version 6 are specifically directed towards simplicity, increasing usability and increasing productivity as illustrated below:

The screenshot shows the ARMD TORSION software interface. Key features highlighted include:

- Auto Convert:** A checkbox in the 'System' menu for automatic unit conversion.
- Mathematical expressions evaluator:** A text field in the 'Insert Value' section containing the formula $=((1.5^2+1.8^2))-3.13$.
- Stiffness Diameter:** A checkbox in the 'Use Stiffness Diam' column of the element table.
- Element Properties:** A checkbox in the 'Dynamic Magnifier' column of the element table.
- Data validation:** A checkbox labeled 'Check for System Errors' at the bottom right.
- Tool Strip:** A vertical strip on the left side containing icons for row manipulation, material change, undo, marking elements, and summary.
- System Table:** A table with columns for Material Number, Use Geometry, Taper, Length, OD1, ID1, OD2, ID2, Use Stiffness Diam, Stiffness Diameter, Stiffness, Damping, Inertia, Use Dyn Mag, Dynamic Magnifier, and Name. Row 2 shows a value of 2.36 in the ID1 column.

- Tool Strip**
- Move row Up
 - Move row Down
 - Split Element
 - Divide element into N elements
 - Change material
 - Undo
 - Mark/unmark elements
 - Color rows
 - Get Summary
 - Reverse order of element on a branch

- **Evaluate Mathematical Expressions.** When entering data to cells, data entry field has the ability to evaluate mathematical expressions, without having to launch a calculator app.
- **Whole Number.** Display for improved legibility, defaulting to scientific notation when required.
- **Auto Convert Units.** Automatically computes the units conversion when modeling a system with different components using mixed SI and English units. Example: You have a few inch dimensions to enter amongst hundreds of mm values, just check the box for auto conversion.
- **Automatic Cell Validation.** Performed at Data Entry time. The program now reviews data grids for incomplete, invalid, or nonsensical entries, providing an Error Flag and correction recommendation. This applies to mass-elastic data fields, user defined torques, and required solver data inputs.
- **Data validation error diagnostics** quickly walks user through any model input errors. A mouse click navigates the user to the next error found.

ARMD™ V6.2 – TORSION Package

- **Row Tagging.** Row marking/tagging for quick identification and rapid recall, advantageous for multi-shaft systems with very large numbers of elements.
- **Round Function.** Round function for data entry fields is accessible from the Tools menu, and can be declared for all data fields.
- **Tool Strip/Bar and Buttons.** Replace hidden right-click menus to provide enhanced visibility of functions and features.
- **Data Entry Grids.** All data entry grids can be open simultaneously for ease of model building.

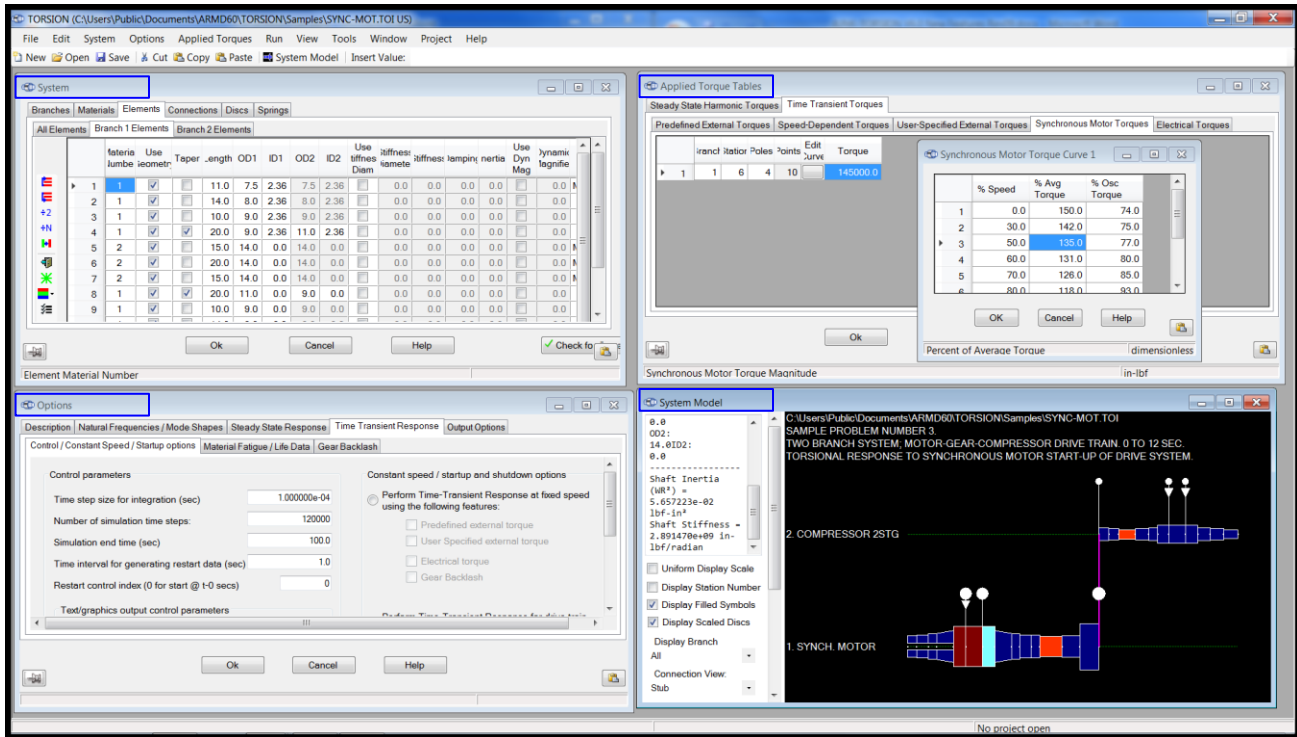
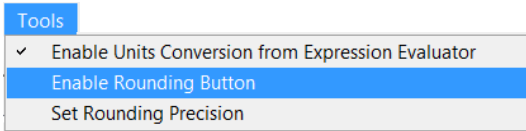

- **Data Entry Menus.** All data entry menus are visible at the Grid input page. Grids now feature selection check boxes and editing buttons where appropriate.

- **One-click Quick Chart.** This feature rapidly displays an X-Y graph of entered tabular data for visual verification of correctness. ARMD Graph software is still available for complete graphic analysis capabilities.

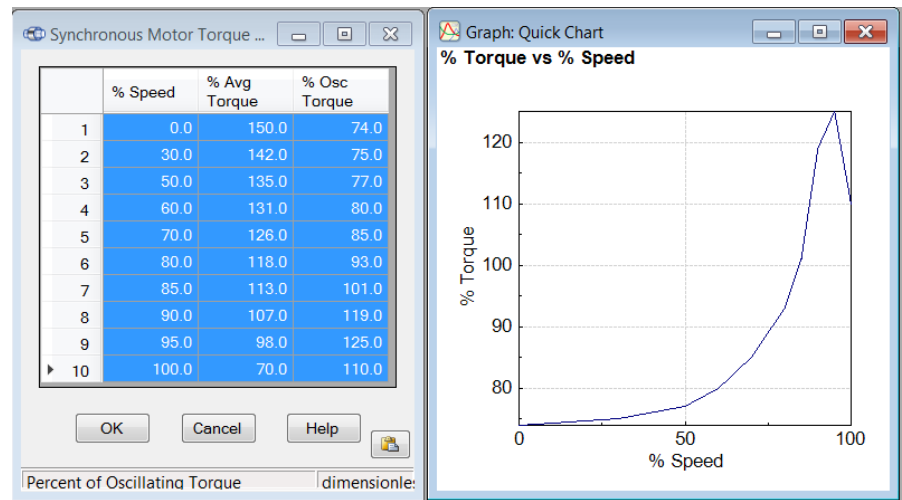

ARMD™ V6.2 – TORSION Package

- **All Branches.** All branch element data is presented on a single grid form allowing simultaneous access to all branch elements of a multi-branch system. This new presentation is much more user efficient for data entry and multi-branch model review.

The screenshot shows the 'System' window with a table of element data. The table is organized into two branches. Branch #1 includes elements 1 through 14, and Branch #2 includes elements 15 through 19. A dialog box titled 'Shaft Element Selection Summary for Rows 8 - 11' is displayed, providing a summary of the selected elements' properties.

Element	Branch Number	Material Number	Use Geometry	Taper	Length	OD1	ID1	OD2	ID2	Use Stiffness Diam	Stiffness Diameter	Stiffness	Damping	Inertia
1	1	1	<input checked="" type="checkbox"/>	<input type="checkbox"/>	11.0	7.5	2.36	7.5	2.36	<input type="checkbox"/>	0.0	0.0	0.0	0.0
2	1	1	<input checked="" type="checkbox"/>	<input type="checkbox"/>	14.0	8.0	2.36	8.0	2.36	<input type="checkbox"/>	0.0	0.0	0.0	0.0
3	1	1	<input checked="" type="checkbox"/>	<input type="checkbox"/>	10.0	9.0	2.36	9.0	2.36	<input type="checkbox"/>	0.0	0.0	0.0	0.0
4	1	1	<input checked="" type="checkbox"/>	<input checked="" type="checkbox"/>	20.0	9.0	2.36	11.0	2.36	<input type="checkbox"/>	0.0	0.0	0.0	0.0
5	1	2	<input checked="" type="checkbox"/>	<input type="checkbox"/>	15.0	14.0	0.0	14.0	0.0	<input type="checkbox"/>	0.0	0.0	0.0	0.0
6	1	2	<input checked="" type="checkbox"/>	<input type="checkbox"/>	20.0	14.0	0.0	14.0	0.0	<input type="checkbox"/>	0.0	0.0	0.0	0.0
7	1	2	<input checked="" type="checkbox"/>	<input type="checkbox"/>	15.0	14.0	0.0	14.0	0.0	<input type="checkbox"/>	0.0	0.0	0.0	0.0
8	1	1	<input checked="" type="checkbox"/>	<input checked="" type="checkbox"/>	20.0	11.0	0.0	9.0	0.0	<input type="checkbox"/>	0.0	0.0	0.0	0.0
9	1	1	<input checked="" type="checkbox"/>	<input type="checkbox"/>	10.0	9.0	0.0	9.0	0.0	<input type="checkbox"/>	0.0	0.0	0.0	0.0
10	1	1	<input checked="" type="checkbox"/>	<input type="checkbox"/>	10.0	9.0	0.0	9.0	0.0	<input type="checkbox"/>	0.0	0.0	0.0	0.0
11	1	1	<input checked="" type="checkbox"/>	<input type="checkbox"/>	10.0	9.0	0.0	9.0	0.0	<input type="checkbox"/>	0.0	0.0	0.0	0.0
12	1	3	<input checked="" type="checkbox"/>	<input type="checkbox"/>	10.0	9.0	0.0	9.0	0.0	<input type="checkbox"/>	0.0	0.0	0.0	0.0
13	1	1	<input checked="" type="checkbox"/>	<input type="checkbox"/>	10.0	9.0	0.0	9.0	0.0	<input type="checkbox"/>	0.0	0.0	0.0	0.0
14	1	1	<input checked="" type="checkbox"/>	<input type="checkbox"/>	10.0	9.0	0.0	9.0	0.0	<input type="checkbox"/>	0.0	0.0	0.0	0.0
15	2	1	<input checked="" type="checkbox"/>	<input type="checkbox"/>	10.0	9.0	0.0	9.0	0.0	<input type="checkbox"/>	0.0	0.0	0.0	0.0
16	2	1	<input checked="" type="checkbox"/>	<input type="checkbox"/>	10.0	9.0	0.0	9.0	0.0	<input type="checkbox"/>	0.0	0.0	0.0	0.0
17	2	3	<input type="checkbox"/>	<input type="checkbox"/>	20.0	3.2	0.0	3.2	0.0	<input type="checkbox"/>	0.0	5.500000e+06	0.0	0.0
18	2	1	<input checked="" type="checkbox"/>	<input type="checkbox"/>	16.0	4.0	0.0	4.0	0.0	<input type="checkbox"/>	0.0	0.0	0.0	0.0
19	2	1	<input checked="" type="checkbox"/>	<input type="checkbox"/>	10.7	4.5	0.0	4.5	0.0	<input type="checkbox"/>	0.0	0.0	0.0	0.0

Shaft Element Selection Summary for Rows 8 - 11

```

Shaft Length = 54.0 inch
Shaft Weight = 967.4572 lbf
Shaft Inertia (WR²) = 10222.04 lbf-in²
Shaft Stiffness = 1.194514e+08 in-lbf/radian
-----
Total Inertia (WR²) = 10222.04 lbf-in² (Shaft + Disc)
    
```

- **Stiffness Diameter.** Can be used to enter the equivalent mass-elastic properties of complex shaft sections, motor lamination stacks, shrunk on disks, etc.

- **Time-Transient User-Defined Torques.** User has complete freedom to specify, including predefined external torques, speed dependent torques, user-specified external

The 'Applied Torque Tables' dialog box displays a table of torque data. The selected row is:

Branch	Station	Start Time	CSV File
1	1	6	My TData_01.csv

The 'Edit Torque Curve' dialog box shows the following torque data:

Time	Torque
0.0005	58364.34643
0.001	1125.967494
0.0015	-74694.25532
0.002	-166022.0528
0.0025	-268783.8141
0.003	-378169.2525

torques, harmonic torques, synchronous motor torques, and electrical torques. User defined external torques can be prepared in a CSV file and linked to the torsional model as shown here.

ARMD™ V6.2 – TORSION Package

- **Shaft Material Temperature.** Material operating temperature is readily input and enabled, to capture the temperature dependent material properties and the effects upon torsional modeling. Particularly useful for shafts in high temperatures applications like steam turbines, rolling mills or extruders.

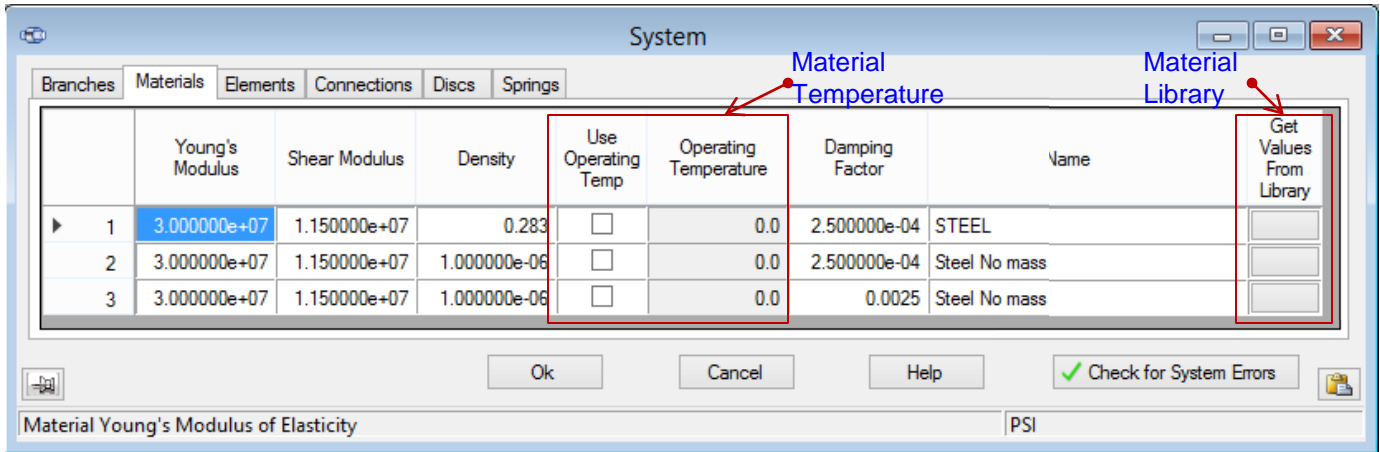

- **Shaft Connections.** Better handling of shaft connections for multi-speed systems. The reference shaft and its associated speed are selectable, allowing the analysts to see speed-based variable-stiffness effects upon the model.

- **Shaft Connections Specification Form.** Optional full linear connection display between shafts with the ability to specify stiffness and damping values, all on one form.

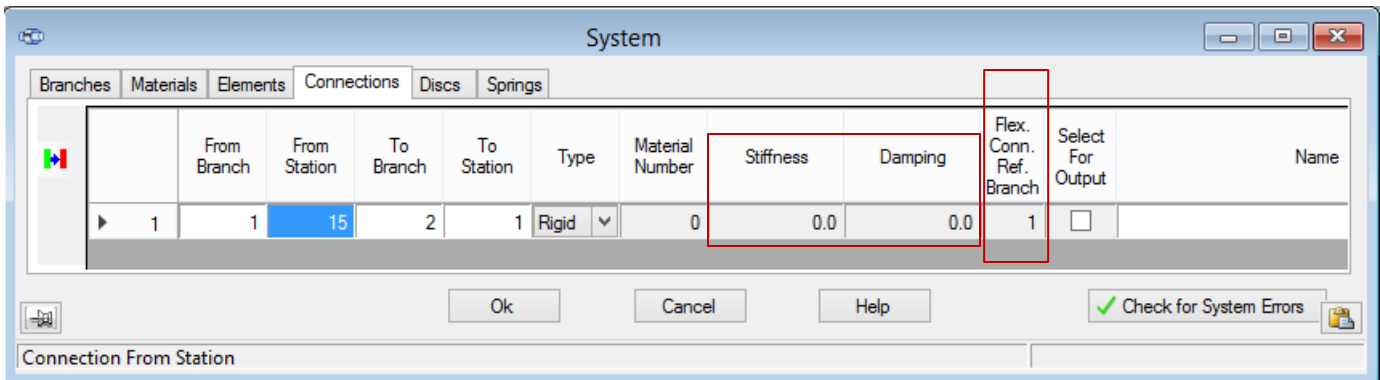

- **Selectable Output Units.** Selectable Frequency Units between CPM or Hz, in accordance with the user's preference, or the industry standard format can be set simply by checking a box in the options form.

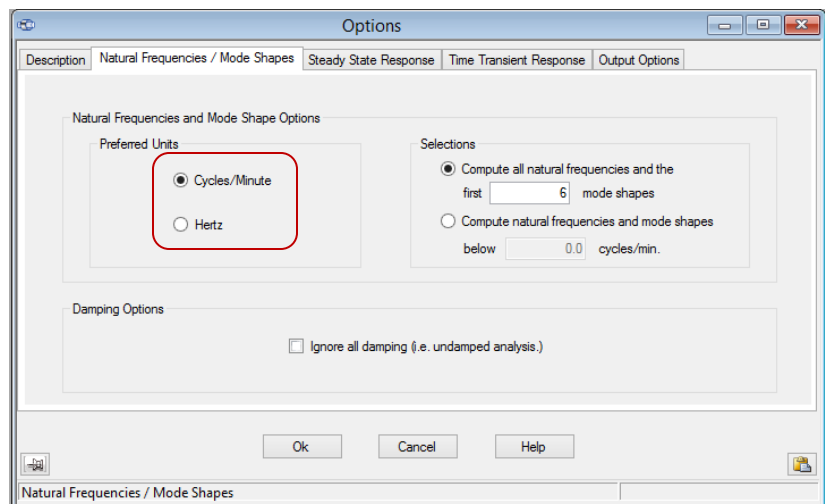

ARMTM V6.2 – TORSION Package

- **Import of Models.** Import a complete TORSION multi-shaft system or only a single shaft from another TORSION input file. Imported shafts can be included on new system models either by inserting into a shaft, or appending to a shaft model. A powerful modeling tool to efficiently model like or similar systems in rapid fashion.

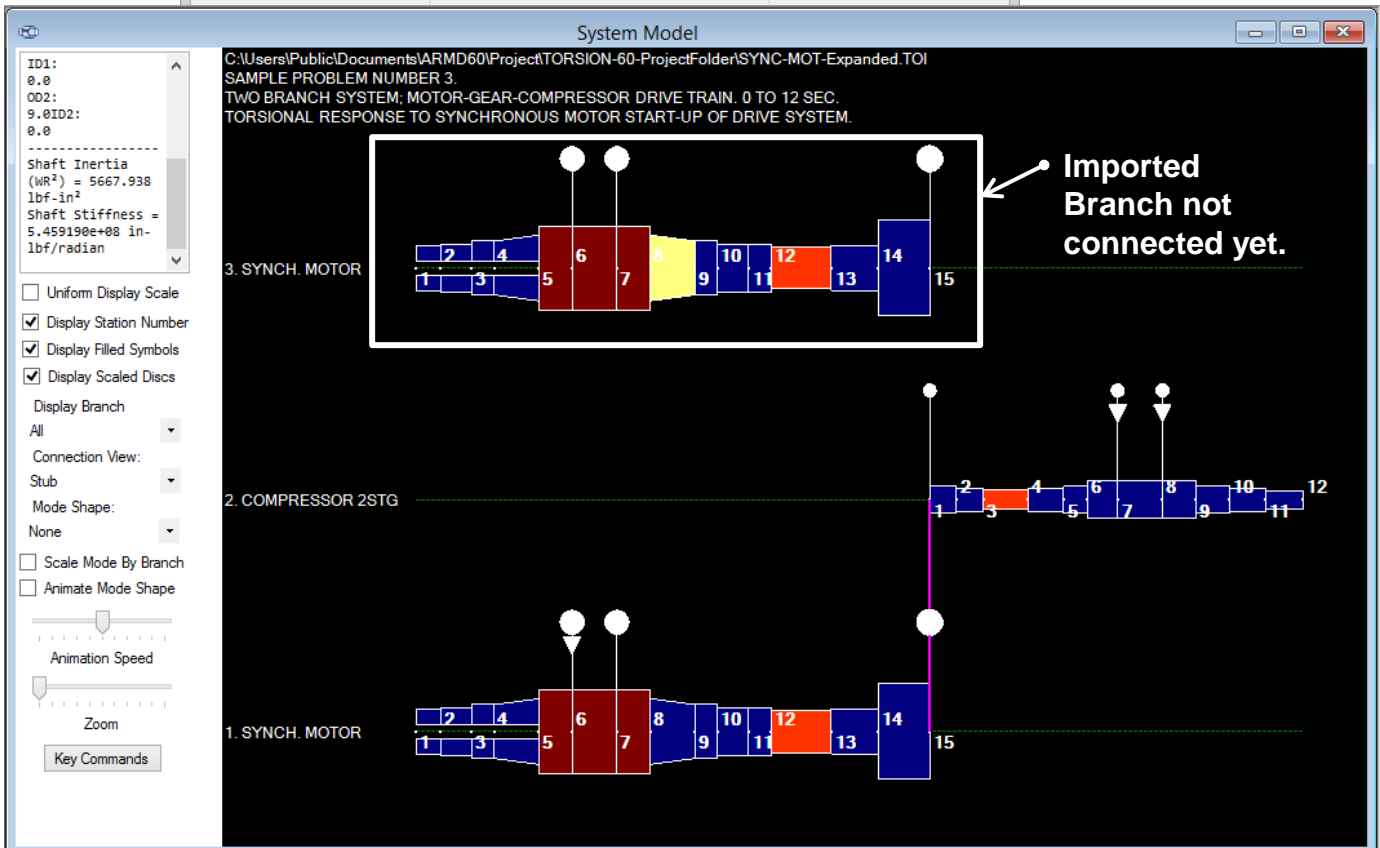
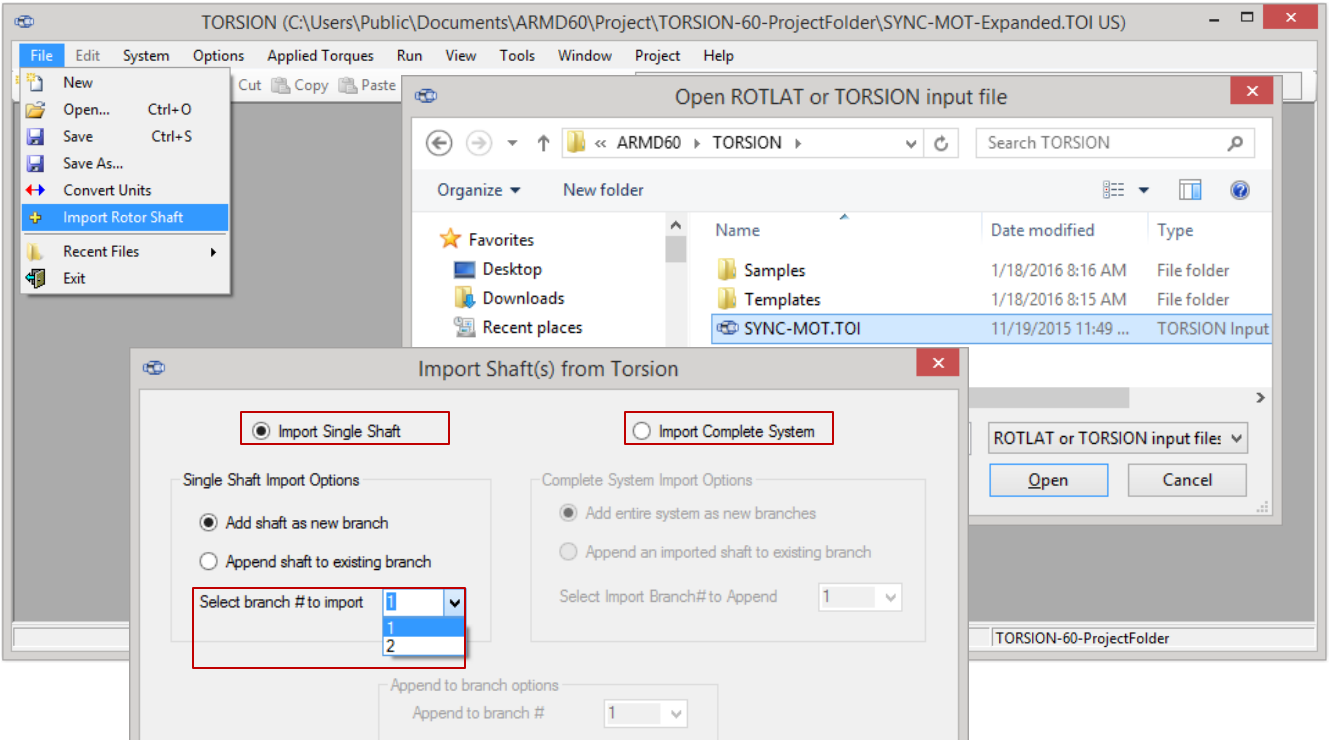

ARMD™ V6.2 – TORSION Package

➤ Import of Models (continued).

- Shaft models can be **flipped from left to right** with a single button click.

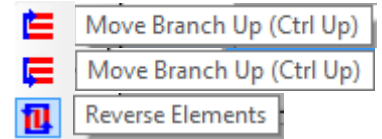
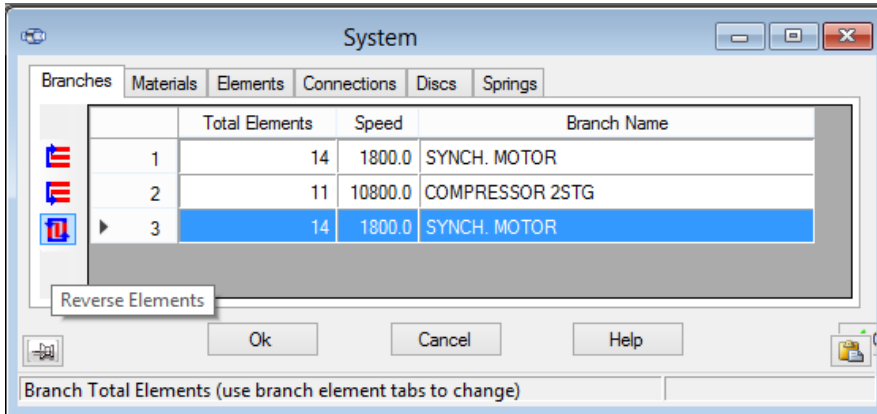

- Shaft models can be **moved up or down** in the system model with a single button click.
- Shaft elements can be **moved along the shaft in either direction** with a single click.
- Shaft elements can be **divided** into a user specified number of smaller elements, while retaining the overall geometry (length, OD, ID, etc.) in the process.

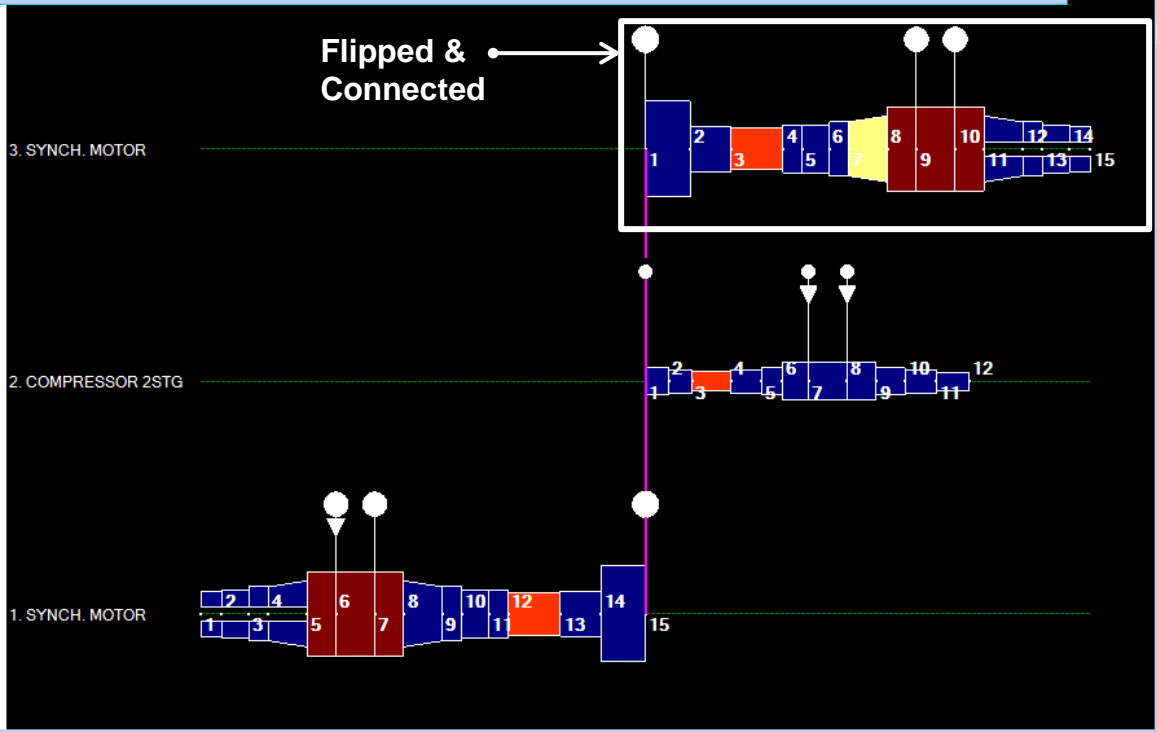
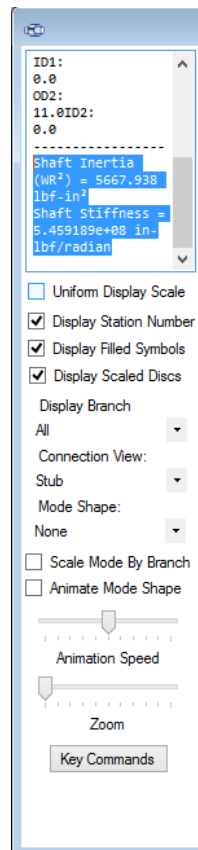
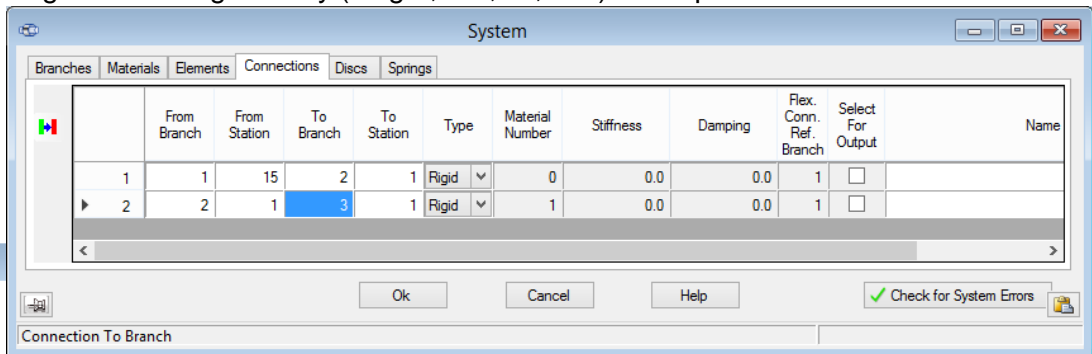

ARMD™ V6.2 – TORSION Package

➤ Import of Models (continued).

Shaft element **data entry grids can be detached** from the System Form to allow multiple shaft element grids to be modified concurrently.

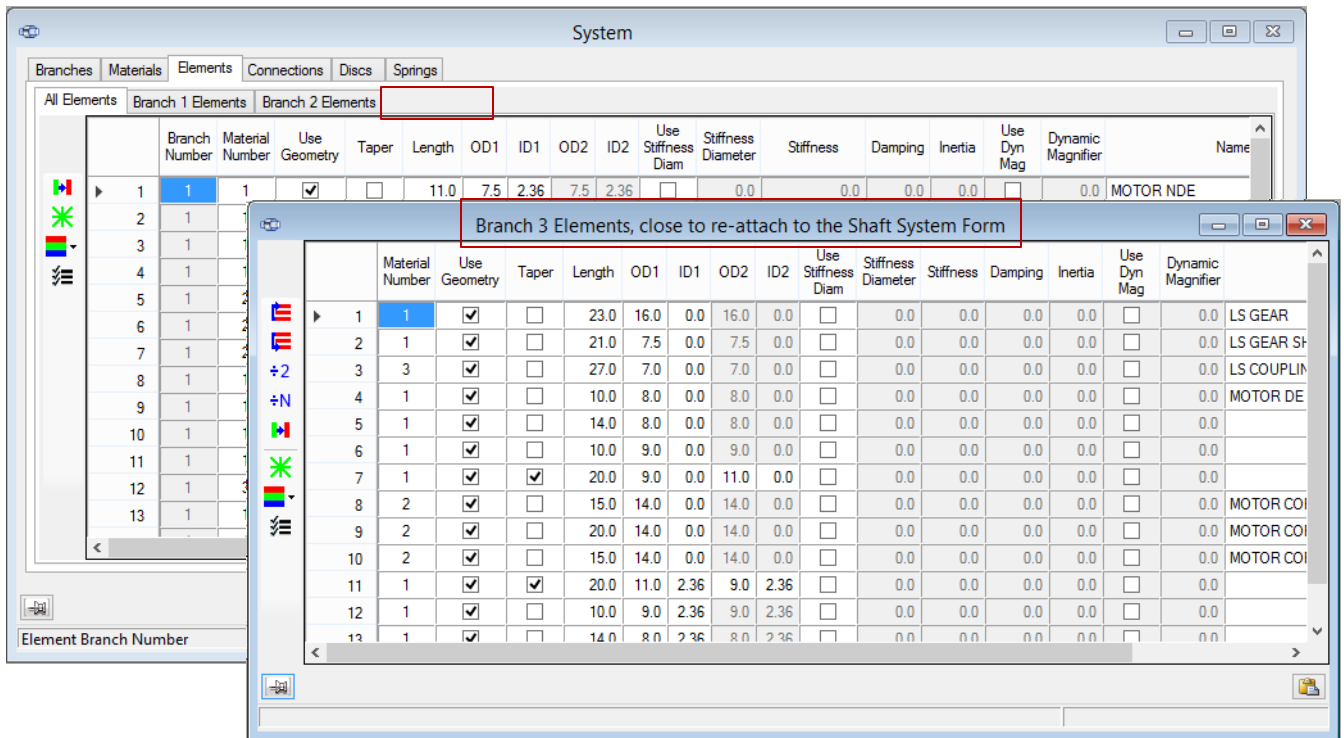

➤ **Create Templates** . Templates can be created for shaft component assemblies for TORSION model input files, allowing for quick access to, and rapid construction of, new multi-shaft systems.

➤ **Text Output Viewer**. User selectable text output viewer that can be Word, Open Office Writer, Notepad, WordPad, or any other program which accepts text file input. Setting are specified in the ARMD Settings form from the help menu.

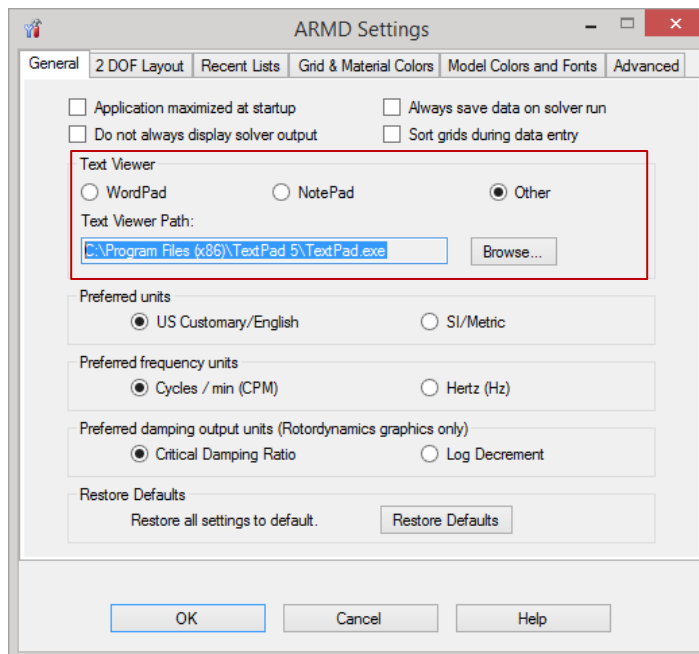

ARMD™ V6.2 – TORSION Package

➤ 2-D GRAPHICS MODEL.

Real-time graphics update of the 2-D image corresponding to numeric data input in data grids provides visual confirmation of model correctness while building system models.

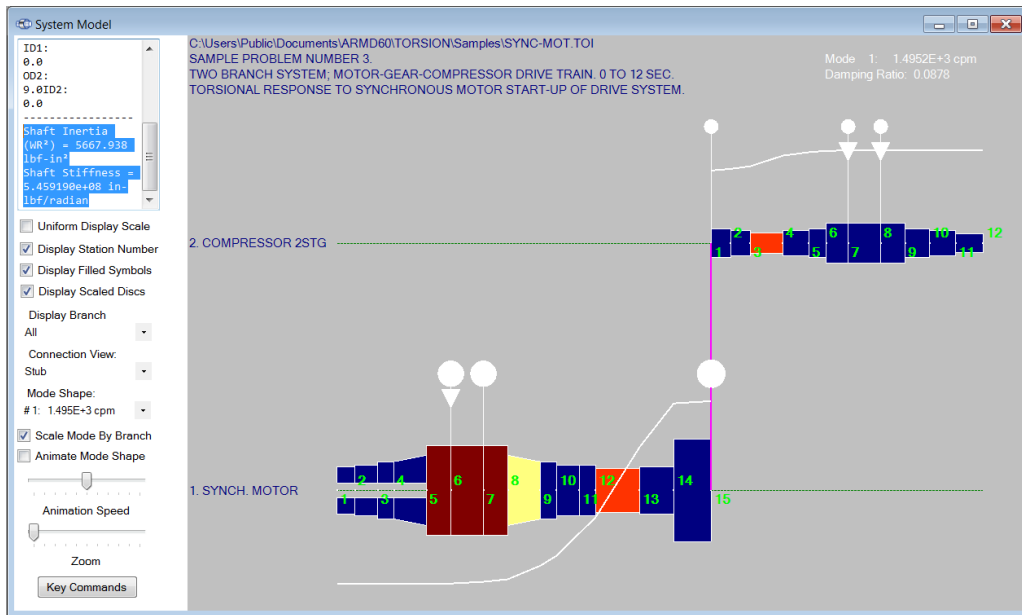

2-D Model auto resizing gives user the option to “fit-to-page” complete models or single branches. User can automatically view the model with the correct aspect ratio, thereby permitting rapid, visual model review.

2-D model viewer mode options now include:

Single Branch View.

Auto Scale to Width for the complete model or a single shaft.

Stub Shaft View to represent large, multi-shaft models in a simplified fashion.

Auto Aspect Ratio presentation.

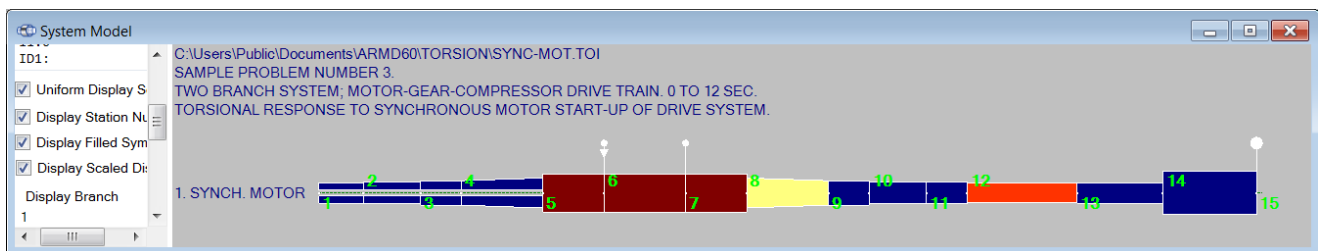

Interrogate an element using the 2-D Model Viewer to see all defining element data in a side-bar data window.

Element selection with control keys within the 2-D model viewer permits easy identification of particular cells within large models. This is useful for closely spaced, thin elements.

Rotated view option for copying the 2-D model graphic to the clipboard.

Metfile enabled copy and paste of system models and graphics for better report graphics.

Tool panel has been added on the 2-D display window for enhanced graphics control and better visibility of display options.

ARMTM V6.2 – TORSION Package

➤ Steady State Response.

Performed at specified speed or as a function of speed with any harmonic excitation at any shaft location.

Results include element torques & stresses, station angular displacement, velocity and acceleration, etc.

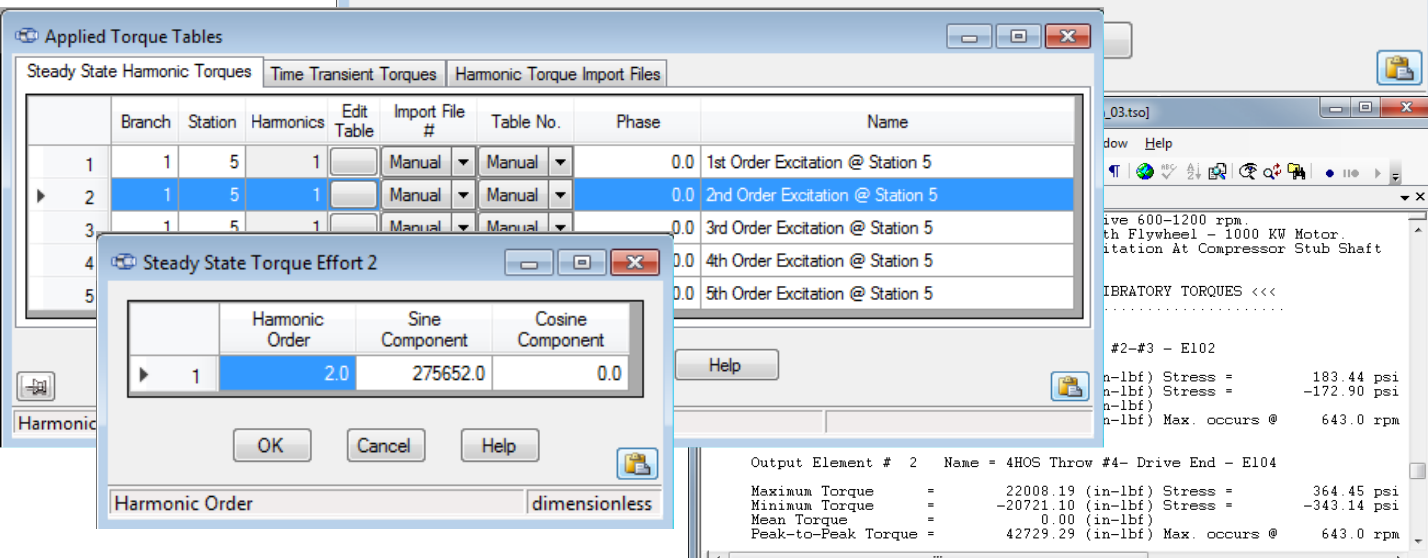
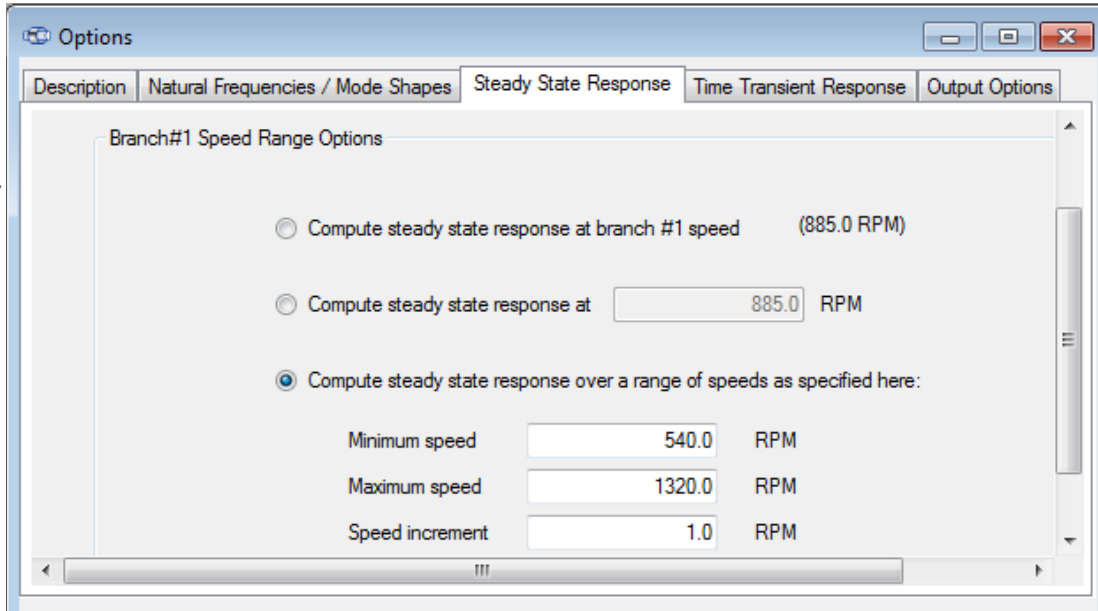

C:\Users\Public\Documents\ARM60\TORSION\torhrm_03.teg

Torque as a function of speed

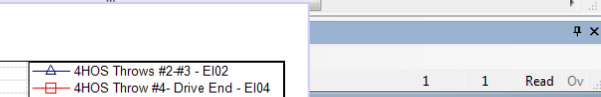
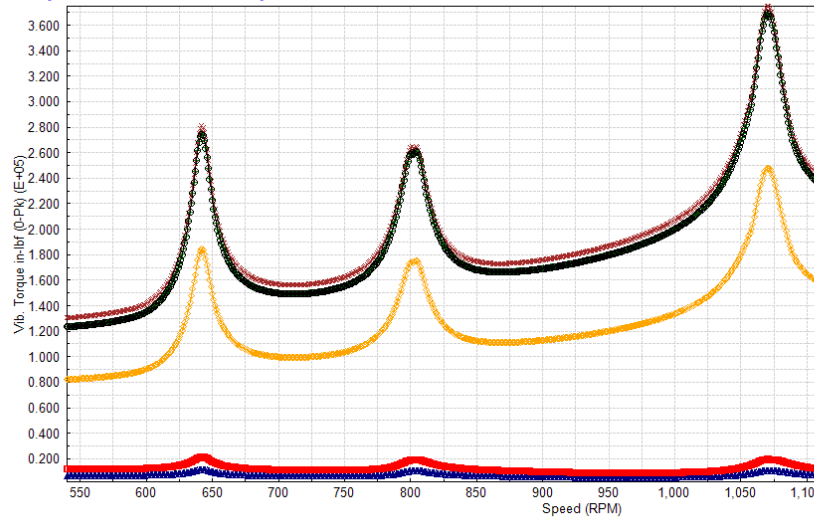

C:\Users\Public\Documents\ARM60\TORSION\torhrm_03.tsg

Displacement as a function of speed

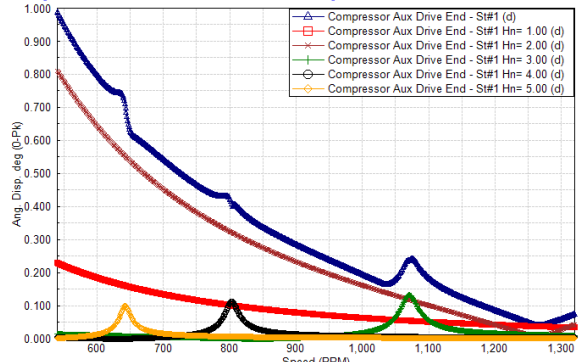

ARMD™ V6.2 – TORSION Package

➤ **Steady State Interharmonic Excitation & Response.** Electric motor controllers used in variable-speed drive (VSD) applications generate integer and non-integer harmonic torsional excitations. Intersections between these harmonic excitations with relevant torsional natural frequencies can create "troublesome" levels of resonant response and, therefore, must be considered. ARMD's TORSION software module provides a complete evaluation of VSD-related harmonic excitations.

Applied Torque Tables

Steady State Torques | Time Transient Torques

Steady State Harmonic Torques | **Interharmonic Excitations**

Branch: 1 | Line Frequency: 60 Hz | Station: 10 | Number of Poles: 2

Excitation Frequency Equation
 $f = |kf_1 + mf_{line}|$
 where f_1 = Inverter Frequency and f_{line} = Line Frequency.

	Sine Component	Cosine Component	K	M	Name
1	350.0	0.0	6	6	VSD Excitation #01
2	0.0	350.0	12	-6	VSD Excitation #02

C:\Users\Public\Documents\ARMD62\TORSION\MotorDriveCompressor_w_InterharmonicTorque.tnc
 CAMPBELL DIAGRAM WITH INTERHARMONIC EXCITATION FREQUENCIES

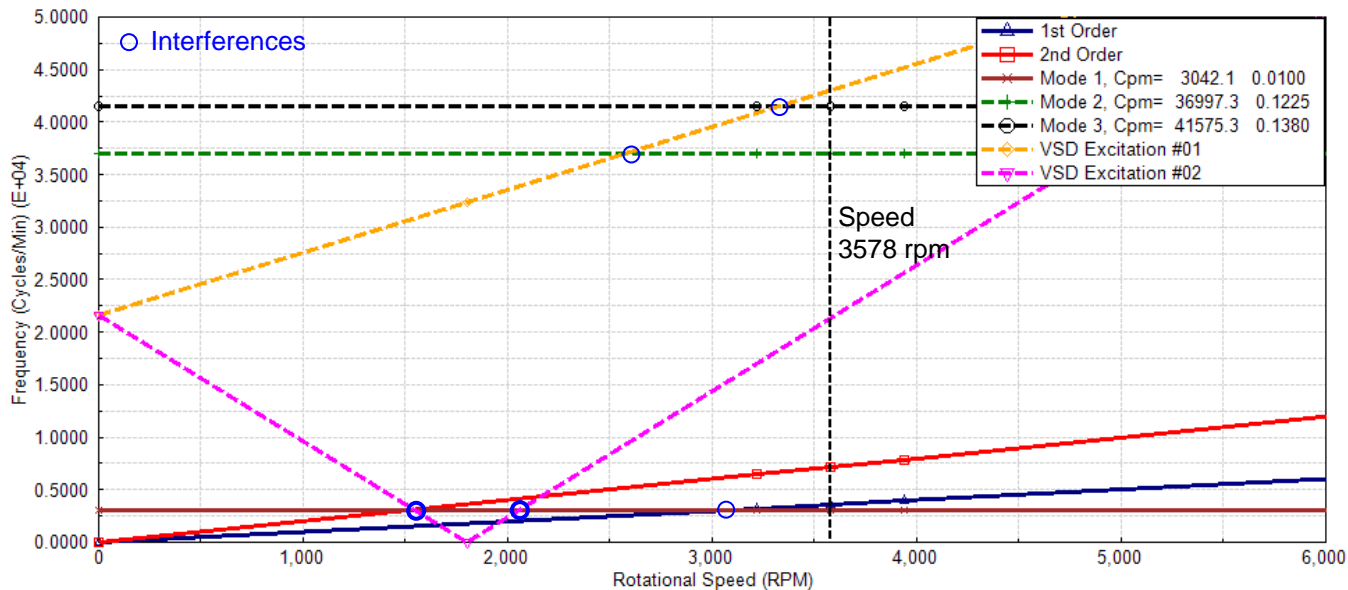

C:\Users\Public\Documents\ARMD62\TORSION\MotorDriveCompressor_w_InterharmonicTorque.teg
 TORSIONAL RESPONSE DUE TO INTERHARMONIC EXCITATIONS DURING STARTUP

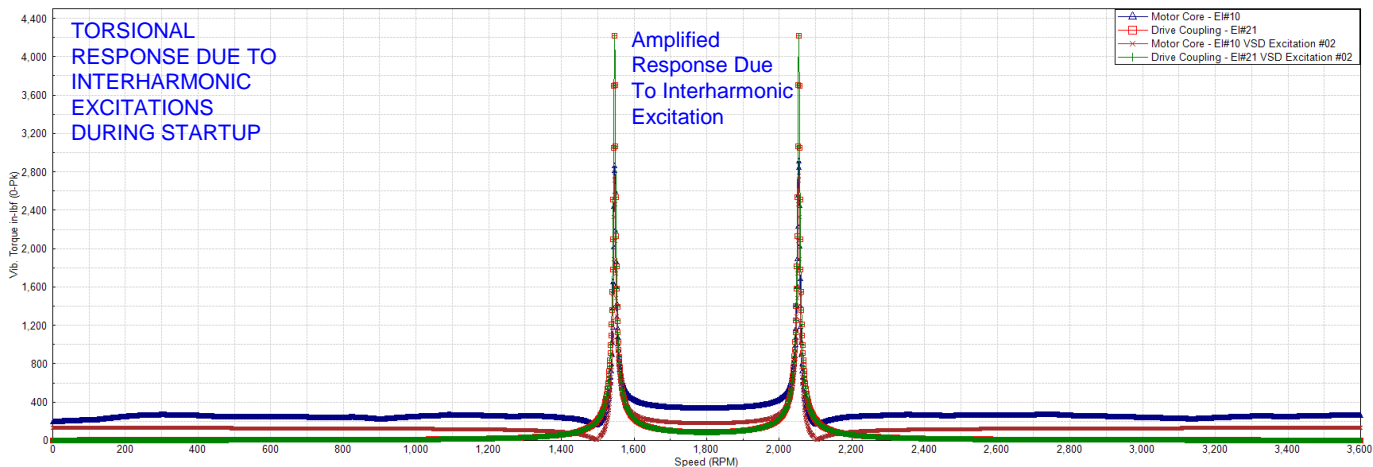

ARMTM V6.2 – TORSION Package

➤ **Generator/Motor Electrical Excitations.** Among the features incorporated in TORSION package are electrically-induced, time-varying exciting torques associated with generator and induction motor operation that include: [Generator](#) [Induction Motor](#)

- 1: 3-phase short circuit
- 2: Line-to-line short circuit
- 3: False coupling short circuit

- 4: Start from standstill
- 5: 3-phase short circuit at terminals
- 6: 2-phase short circuit at terminals
- 7: High-speed automatic reclosing

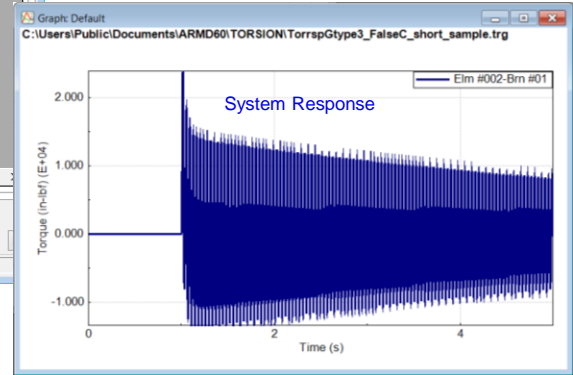
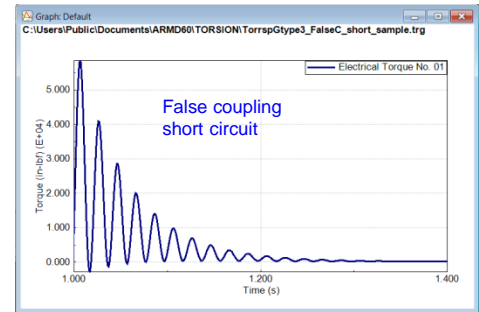
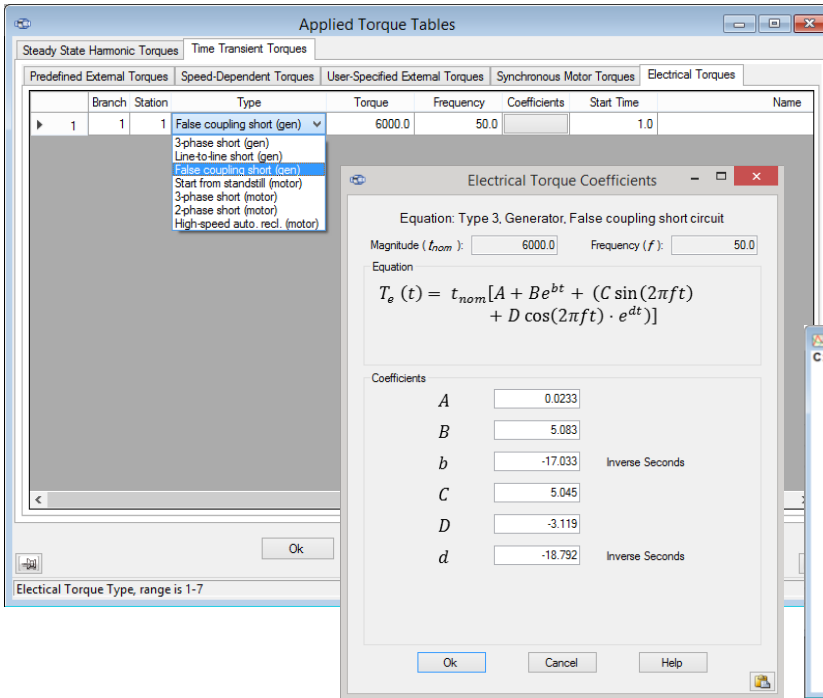

➤ **Startup characteristics** of synchronous motor, user-specified time-transient external-torques, & calculated system response are available in the graphics output file.

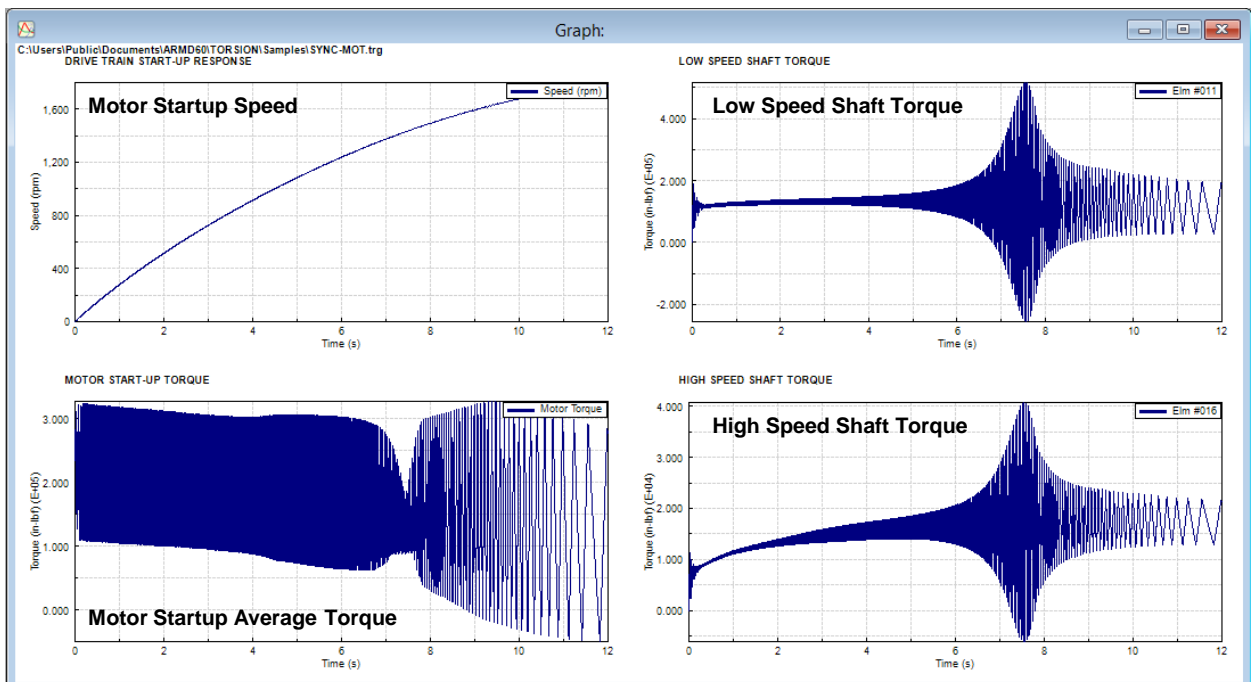

3-D Shaft Viewer Utility (ARMDShaftViewer)

ARMD Shaft Viewer is a 3-D rotor system graphics utility integrated in the ARMD suite. It uses modern 3-D graphic rendering technology to provide a highly realistic view of rotating assembly models and drive train system models. In addition, dynamic performance results generated by the rotor dynamics module ROTLAT and torsional vibration analysis module TORSION can be presented. Displayed models and their dynamic performance results can be rotated, zoomed, moved and animated to provide the user with an efficient and enhanced view of the system dynamic characteristics. The ARMD Shaft Viewer **workspace** is shown below.

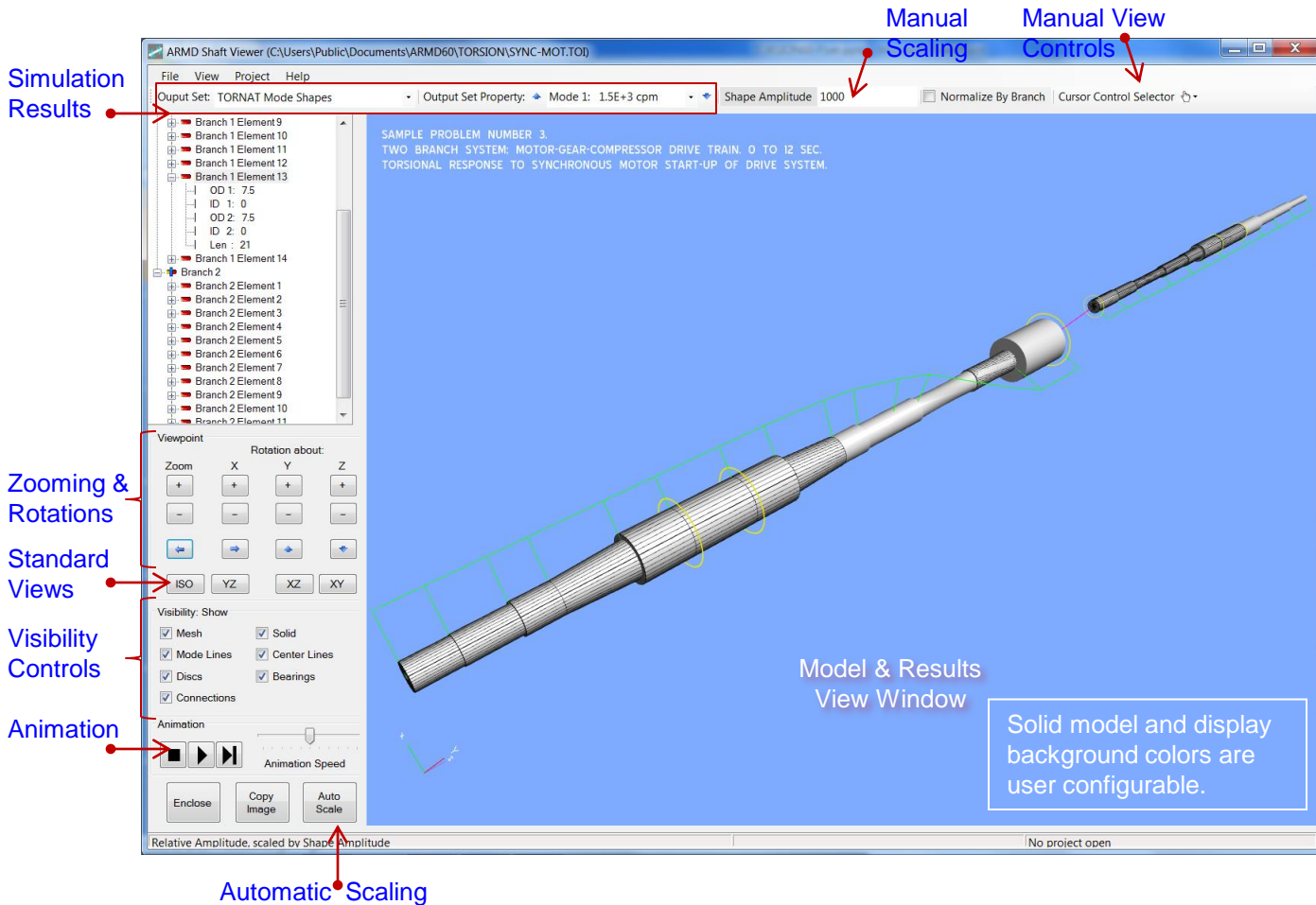

The Shaft Viewer can be run as a stand-alone display utility either from the ARMD main menu or from the computer's Start menu. It is also fully integrated into the ROTLAT Rotor Dynamics and TORSION Torsional Vibration modules, where it is automatically loaded/accessed via the View menu.

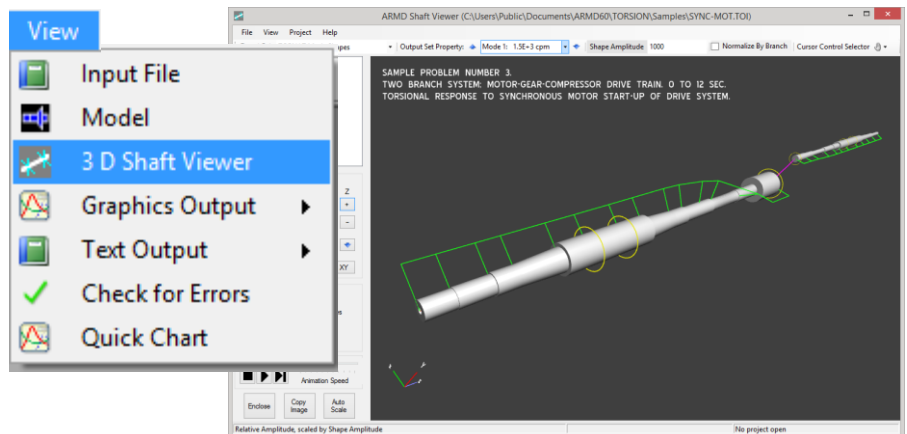

The default opening view is isometric (ISO). Viewpoint is modified using the buttons for zooming and rotation on the left side of the display. By pressing the + and - buttons, the display can be zoomed or rotated about any of the three axes. The arrow buttons in the middle of the Viewpoint group move the display left, right, up, and down. Continuous motion can be achieved by holding any of the arrow buttons down. The display can be reset at any time to one of 4 standard viewpoints, the default ISO view, or projections on the YZ, XZ, or XY planes. The Enclose button re-centers the model without changing its orientation.

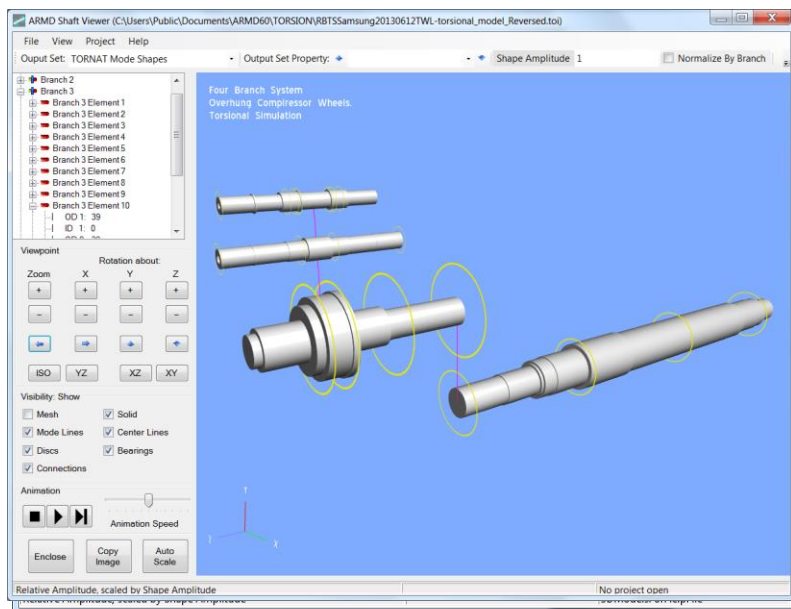

Various elements of the model can be selected for display using the check boxes in the Visibility control group. When Solid and Mesh items are selected, the viewer performs an automatic level-of-detail (LOD) calculation to determine when the mesh is too dense. If required, the software then suppresses the mesh display automatically.

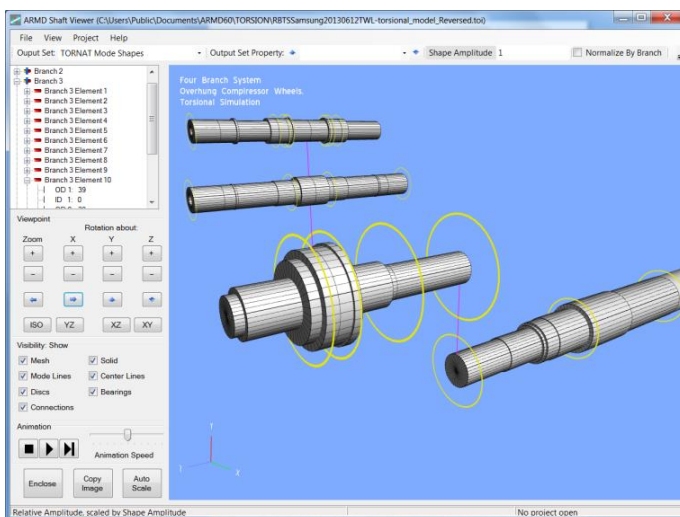
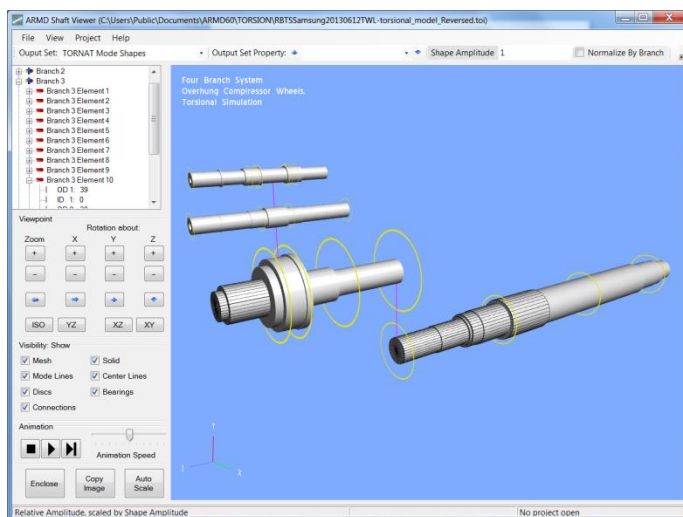

The screens shown above and to the right, first show the mesh suppressed on part of the model followed by full mesh as we zoom in.

If the solid display is not selected, but the mesh is, then the LOD calculation is not performed and the mesh is shown for all elements.

Shaft element information can be found in the shaft element display when an element is selected.

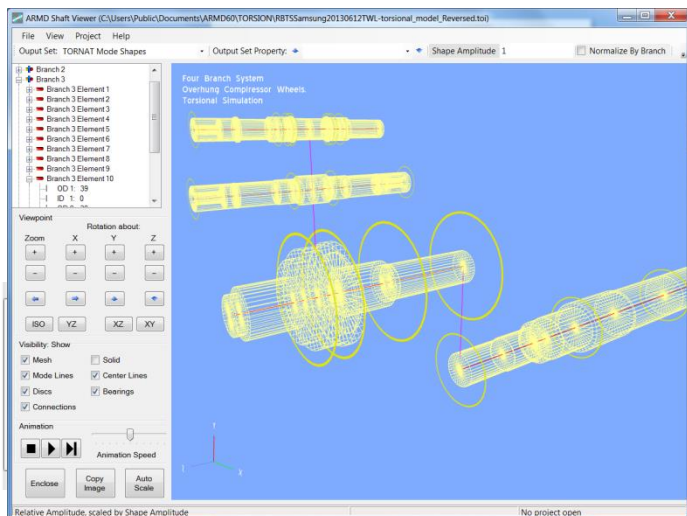
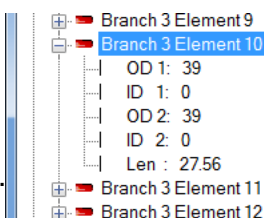

Among the main features of the Shaft Viewer is its ability to display and animate the motions calculated by the various ARMD solvers. When the Shaft Viewer loads a ROTLAT or TORSION shaft system model, it automatically looks for supported solver output files. No user interaction is needed. These output sets are then presented to the user for display in the *Output Set Property* drop-down box on the viewer's main toolbar.

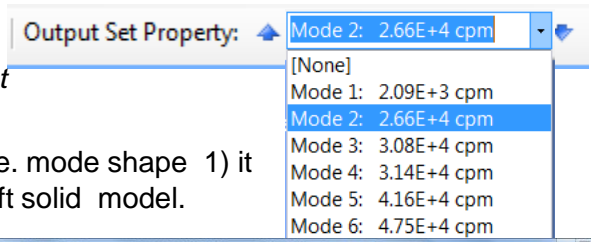
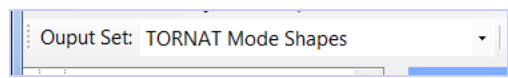

Once an output set and property has been selected (i.e. mode shape 1) it is displayed as shown below, with and without the shaft solid model.

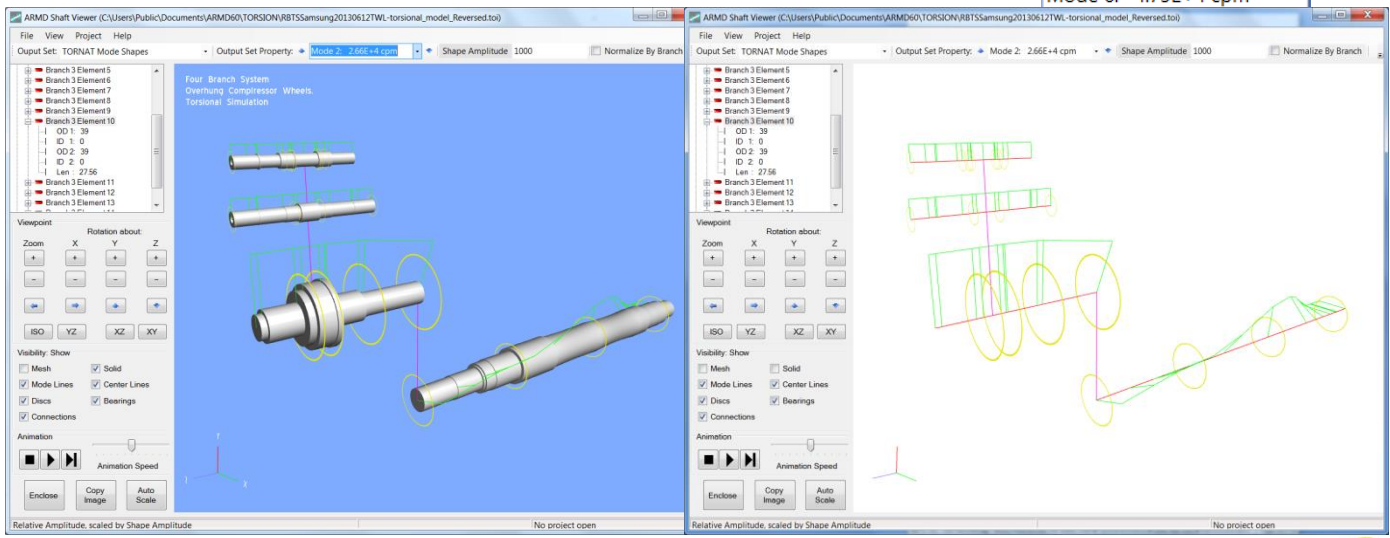

For enhanced visualization of torsional vibration analysis results, such as mode shapes, presentation is an angular twist about the rotational Z axis. The angular twist displayed has a maximum range of +/- 45 degrees and the twist lines extend out beyond the model surface by a factor of 1.25 times the shaft's maximum OD.

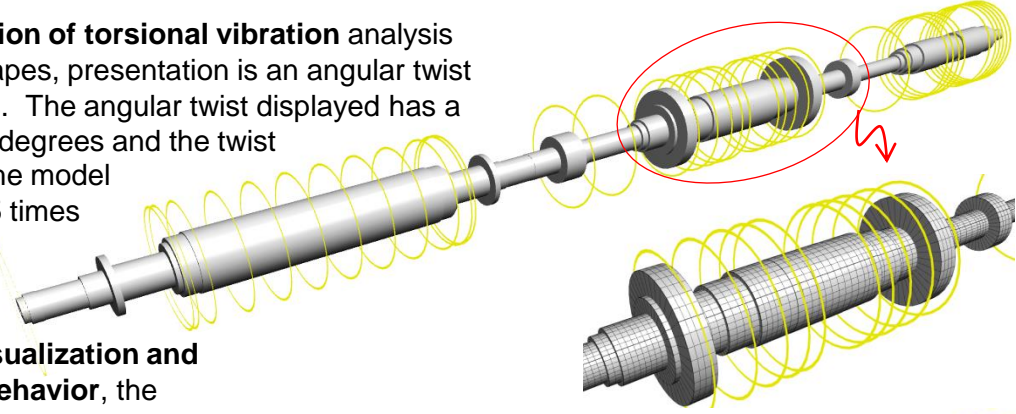

For long drive trains, visualization and animation of torsional behavior, the angular twists displayed have a maximum range of +/- 90 degrees and the twist lines extend out beyond the model surface by a factor of 2 times the shaft's maximum OD as shown here.

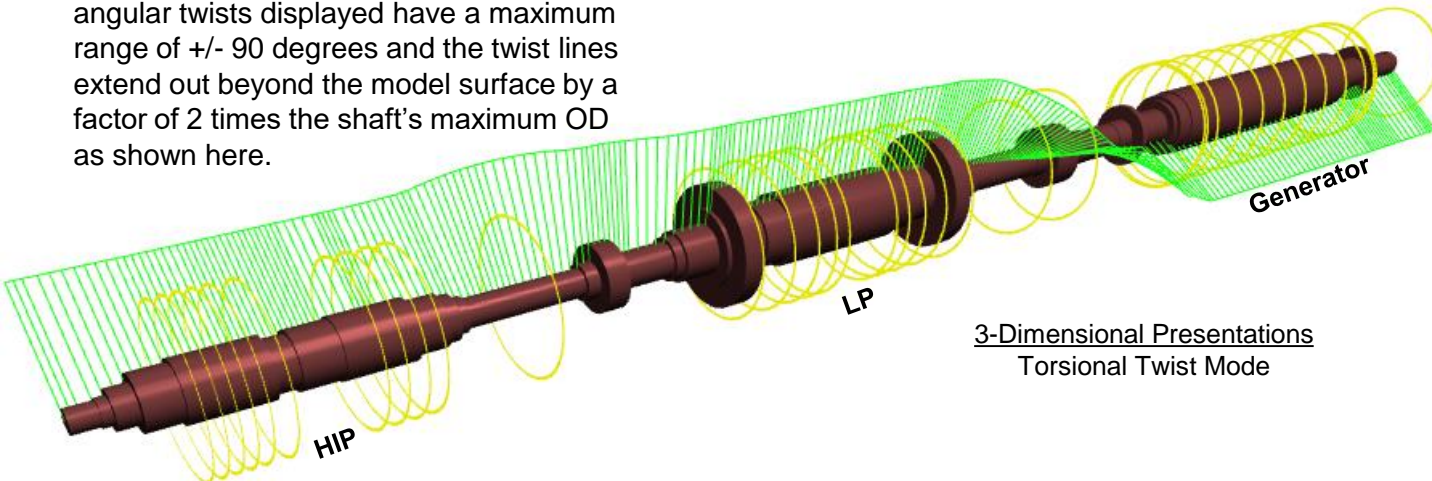

3-Dimensional Presentations
Torsional Twist Mode

2-D Graphics Utility (ARMDGraph)

ARMDGraph is a graphics utility that employs a Workspace concept to manage multiple graphs with associations to single or multiple graphics output files. The workspace environment contains all user defined plot and chart configuration settings for graphics output files generated by

ARMD solvers. The workspace configuration form consists of two panels. The left panel contains a tree view of the graphs, charts, and graphic output files. The right panel contains all chart and graph settings.

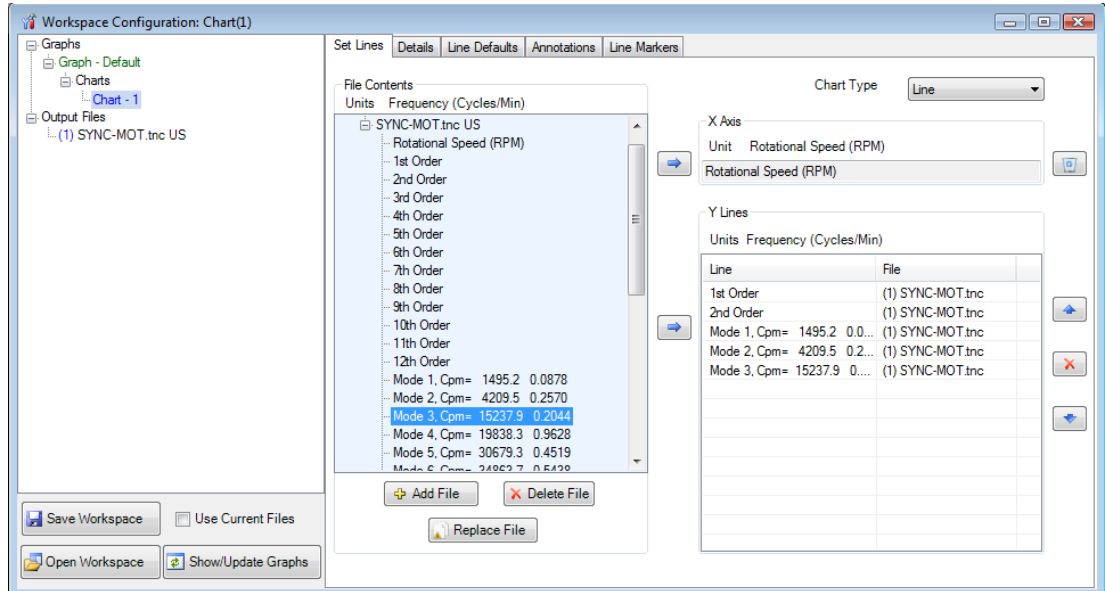

ARMDGraph features include:

- Workspace concept that contains all graph settings and linked graphics output files in one form customized by the user.
- Existing workspace can be easily applied to newly generated graphics output files.
- New graphical user interface to access and customize graphs.
- New file format (*.usrx) allows more customization of graphics data than previous (*.usr) format.
- Ability to create multiple graphs each of which may contain multiple charts.
- Ability to plot from two or more graphics output files.
- Backwards compatible with files generated by RBTSGRAF (*.usr) graphing utility.
- Customizable annotations and line markers.
- Automatic detection of graphics data file changes and updates.
- Plots can be rotated and copied to the clip board as bitmaps or enhanced metafiles.
- Utilizes GUI help system.
- Accelerator keys for accessing menu items and switching between charts.
- Multiple plots per window (1, 2, 3 or 4) including line, polar, and FFT plots.
- Templates for automatic configuration of graphs.
- Save/restore user options (*.USRX), for custom graphs, including:
 - Log, semi-log or linear axis scaling.
 - Grid lines (ON or OFF).
 - Draw curves with lines, symbols or both.
 - Automatic or manual axis scaling.
 - Legend position (hidden, inside or outside right).
 - Macro strings for flexible title assignment.

Graphics Utility (ARMDGraph)

With ARMDGraph, in few simple steps a workspace can be set up, saved and a graphical representation of simulation results from ARMD solvers can be generated as illustrated below.

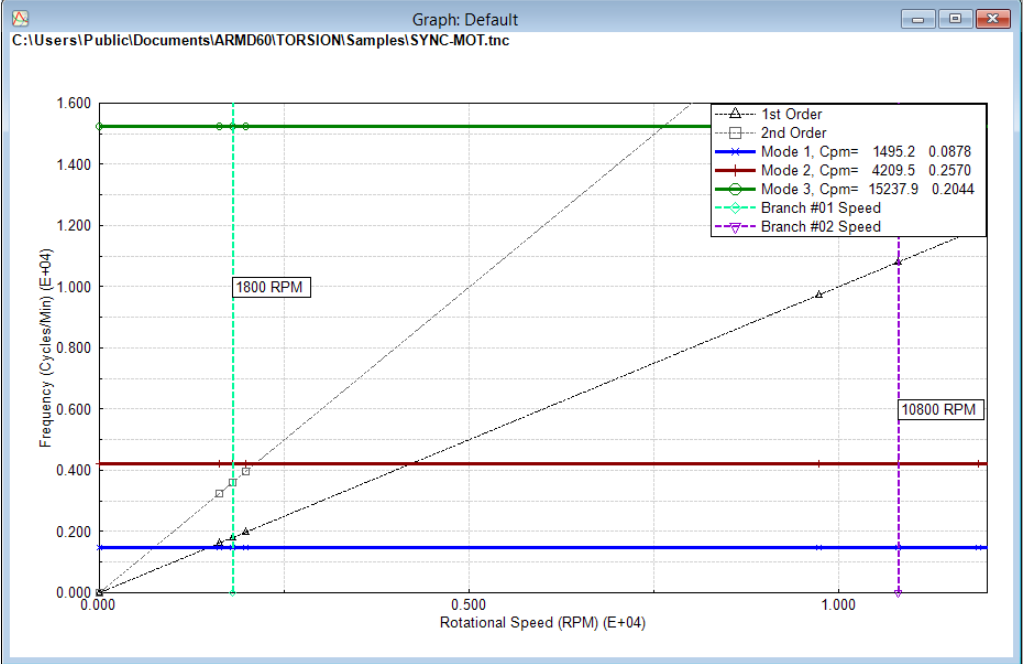
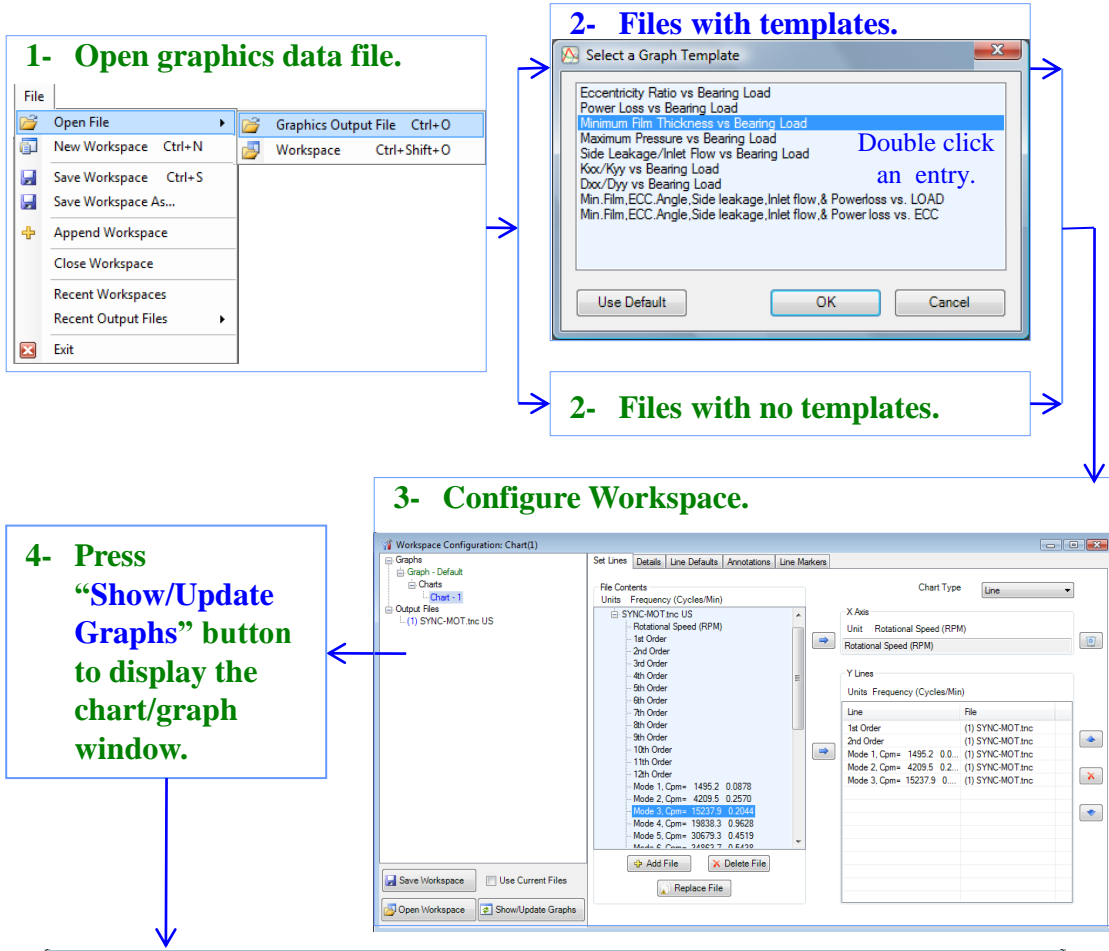

Purchasing Options

ARMD is constructed from various solution modules. It can be tailored to suit your needs and budget. You may purchase any combination of programs/modules or all if you wish. Licensing is available as a single seat or multi-seat network configuration. With your purchase, the package includes the software (CD or download), quick start manual, electronic user's manual, technology transfer and training session (optional), updates, maintenance, and support.

System Requirements:

Personal computer with Microsoft Windows 8, 10, 11 or higher (32 or 64 bit).

Remember, with **RBTS**, you get more than just the programs, you get the company with more than 50 years of experience in the areas of tribology and machinery dynamics.

For further information, please contact us.

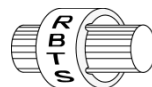

RBTS, Inc.

Rotor Bearing Technology & Software
1041 West Bridge Street
Phoenixville, PA 19460
USA

Telephone: **610-415-0412**
Facsimile: **610-415-0413**
Web: **www.rbts.com**
Email: **info@rbts.com**

ARMD[™] - The Worldwide Leading Software For Rotating Machinery Analysis

Advanced Rotating Machinery Dynamics

ARMD is a well established software package used worldwide to perform complete rotating machinery dynamic analysis. **ARMD** employs a user-friendly interface and window environment with pull-down menus and context-sensitive help. **ARMD** integrates the most advanced and complete rotor dynamics, torsional vibration, and bearing analysis programs under one environment in a seamless fashion to give you the power to model your rotating machinery with ease, efficiency, and above all accuracy. Some applications in which **ARMD** has been utilized include rotating machinery such as a miniature air turbine for a dental drill, a large turbine generator set for a power plant, a small compressor for an air conditioner, a pump for an artificial heart, a fuel pump for a jet engine, an electric motor and spindle for a miniature computer hard disk, a canned pump for petrochemical processing plant, synchronous motor driven drive-trains, and a gear box for an Uranium enrichment plant.

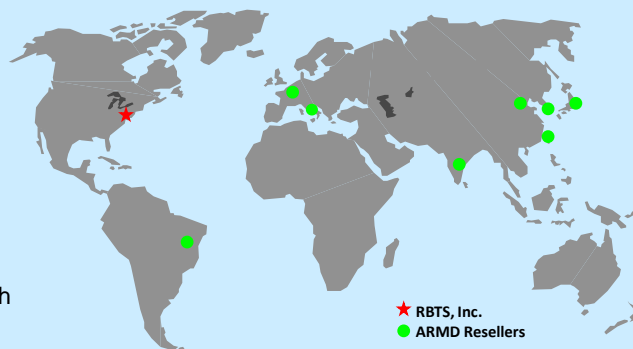

RBTS' software has gained international reputation for its:

- ◆ **Technical Capabilities**
- ◆ **User Friendliness**
- ◆ **Completeness**
- ◆ **Support & Service**



RBTS, Inc.

Rotor Bearing Technology & Software
1041 West Bridge Street
Phoenixville, PA 19460, USA

Please contact **Dr. Andreas Laschet** as RBTS' consultant and representation for the regions **Europe, Middle East, Africa** with the following communication details:

Laschet Consulting GmbH · Friedrich-Ebert-Str. 75 · 51429 Bergisch Gladbach · GERMANY
Phone: +49 2204 84-2630 · E-mail: info@laschet.com · Web: www.laschet.com



YOUR PARTNER

for Europe & Middle East & Africa

Support for other countries on request.

- **Customer Engineering Support**
(Rotor Dynamics & Torsional Vibrations)
- **ARMD Software Support**
- **Training Courses & Seminars**



Please contact: Dr. Andreas Laschet

Laschet Consulting GmbH

Friedrich-Ebert-Str. 75 · D-51429 Bergisch Gladbach · GERMANY

Ph: +49 2204 84-2630 · E-mail: info@laschet.com · www.laschet.com